

# Estonian example of integration e-government services

**Ahto Kalja**

**Tallinn Univ. of Technology, Ehitajate tee 5, 19086,  
Tallinn, Estonia/**

**Estonian Informatics Centre, Rävala 5, 15169 Tallinn,  
Estonia**

**[ahto@cs.ioc.ee](mailto:ahto@cs.ioc.ee)**

# Content

I Introduction

II The general architecture of eGovernment environment in Estonia

III Results of Estonian eGovernment projects

IV Special citizens web portal with db-services

V Estonian ID card and PKI infrastructure

VI eServices

VII A new generation eService “Parental benefit” in Internet

VIII Statistics

IX Conclusions

# I Introduction

eGovernment in Estonia got started by developing a functional architecture that includes:

- secure data transport backbone X-Road,
- distributed information systems functionality and
- different hardware and software components like portals, elements of public key infrastructure (PKI), governmental databases and information systems.

This is the very basis of hundreds of services that have been created today. The recent success with eGovernment services and the common architecture of eGovernment will be given in our presentation.

## II The general architecture of eGovernment environment in Estonia

The architecture of eGovernment was developed in the framework of the X-Road project.

X-Road project was preliminarily initiated for interconnecting Estonian governmental databases to the common data resource accessible over the Internet.

After the successful start of sending database queries and answers over the Internet, the X-Road environment was expanded to send all kinds of XML-format electronic documents securely over the Internet.

At the same time the X-Road started to become a skeleton of all the eGovernment services.

# Information systems

# Banks

# X-road centre

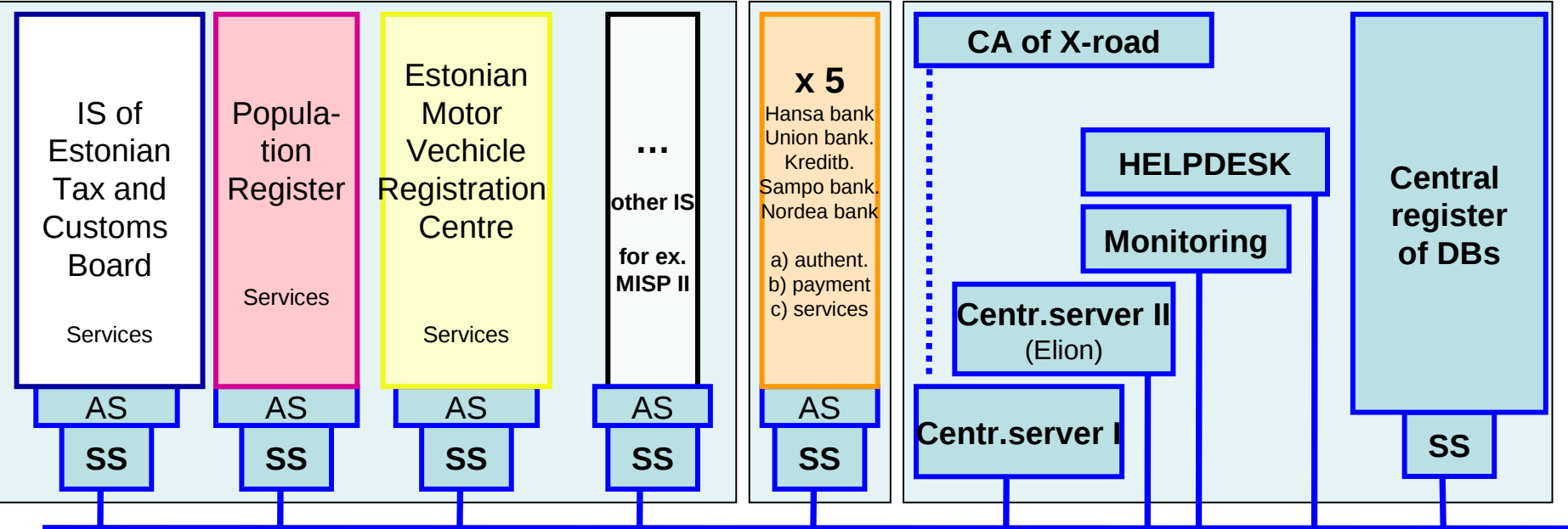

# X-road

# Internet

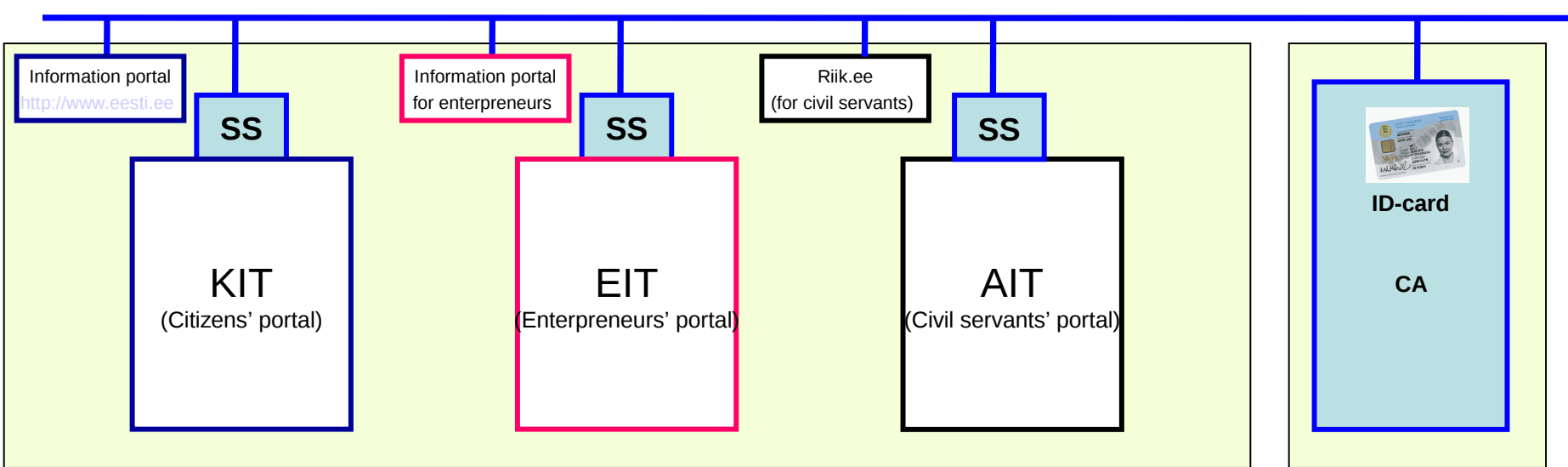

# Environments developed by government

# Certification agency

## 3-layers architecture I

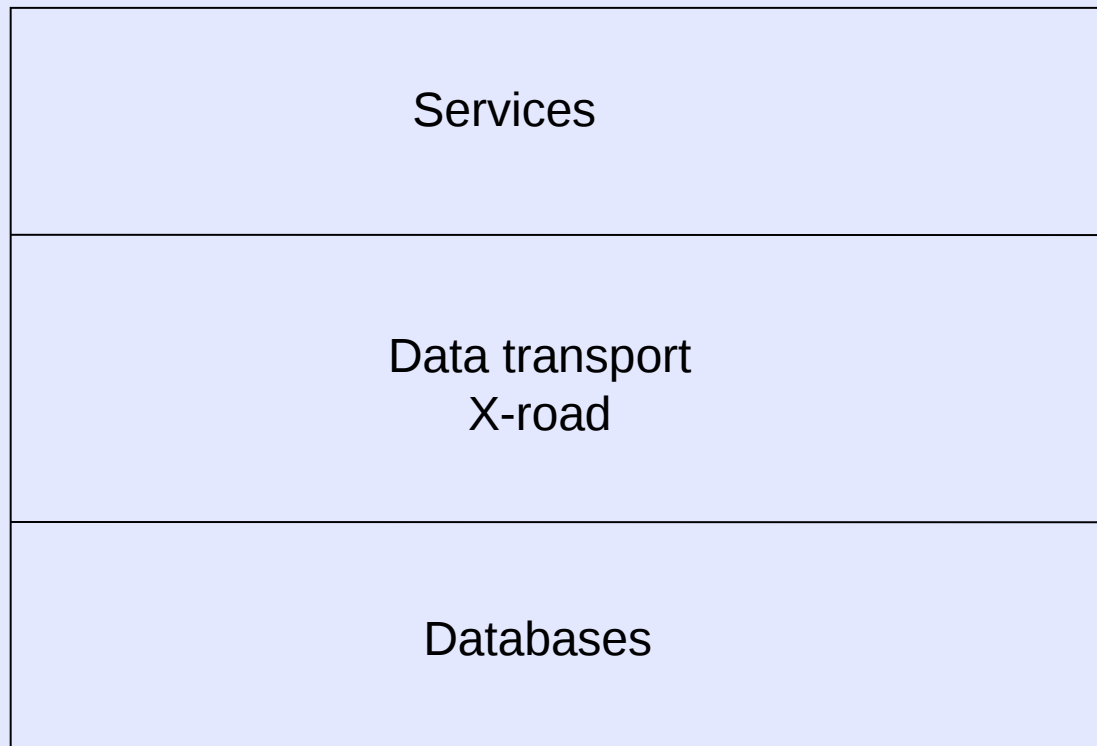

## 3-layers architecture II

Technology

Components

III layer	WSDL UDDI	Services	Parental benefit My vehicles My penalties ...
II layer	SOAP XML RPC LDAP ...	Data traffic X-road	Security server Central server MISP Citizen portal ...
I layer	Oracle Progres MySQL ...	Databases	Traffic register Population register Passports register ...

## III Results of Estonian eGovernment projects

During the last 3-4 years we have finished different IT projects for implementing government architecture in the public sector of Estonia. As the result of the mentioned projects, the following service portals, environments and frameworks are now available in Estonia:

- Special citizens web portal with db-services. Portal has won an award **Finalist with Honourable Mentions** of the **eEurope awards for eGovernment 2003**. The portals eServices will step-by-step be added to the citizen portal (KIT) in the nearest future;
- Framework of the facilities for using Estonian ID-card (over 70% of Estonian population has already an electronic ID-card) with PKI technology for identification, authorization and digital signature operations;
- Citizens, civil servants and entrepreneurs web portals with almost 700 different eServices from different Estonian central and local governments.

Later we will describe some of these environments projects more precisely.



## IV Special citizens web portal with db-services

All services available through the citizen's portal have a common user interface, which is not dependent on a database management system for back office.

A standard authentication system for all citizens has been developed as well.

The set of standard services available include typical queries, such as:

- "give me my data" from the population register;

- "give me my data" from the motor vehicles register.

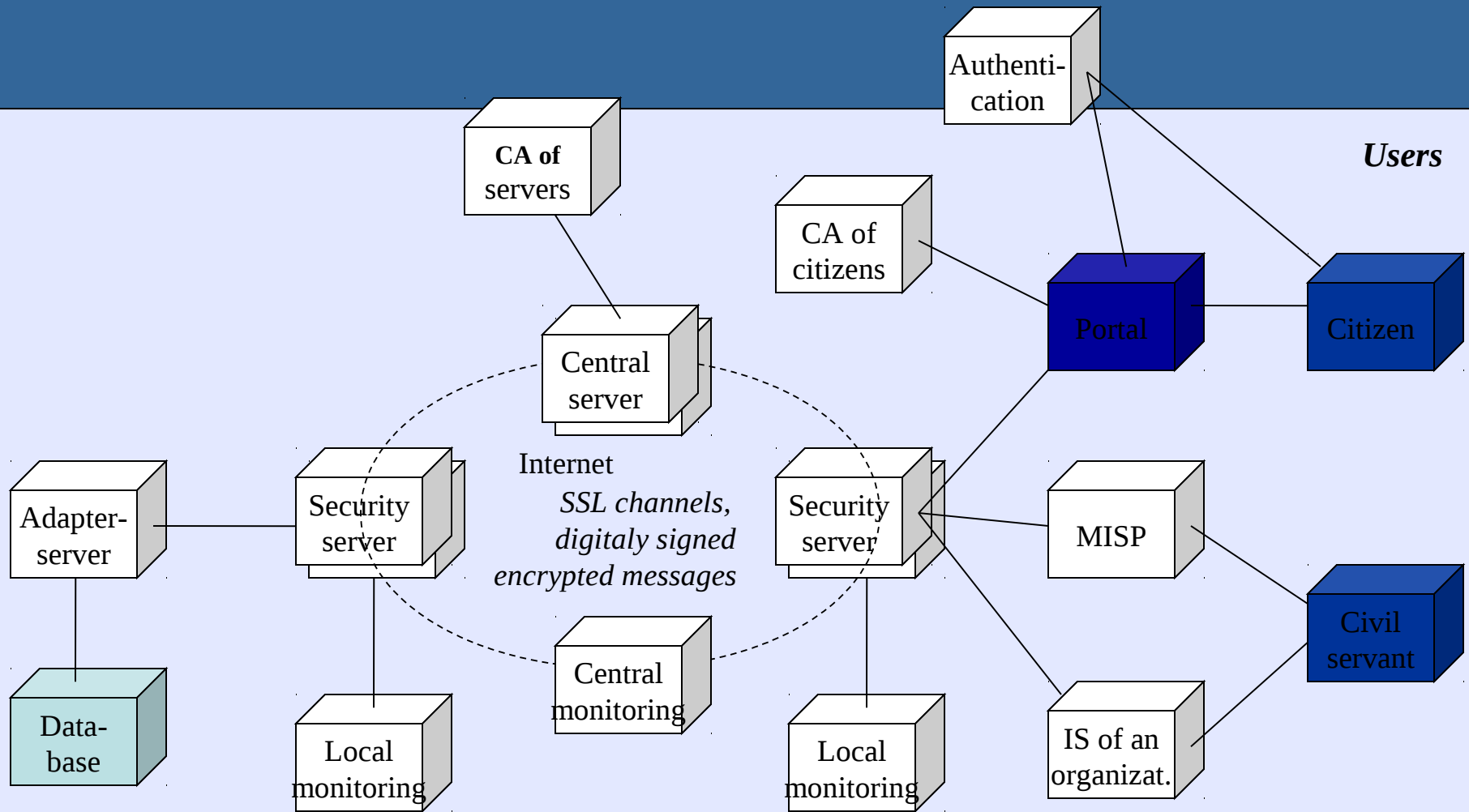

*Functional scheme*

# V Estonian ID card and PKI infrastructure

The purpose of Estonian ID-card project was to use nation-wide electronic identity and develop a new personal identification card that would be a generally acceptable identification document and contain both visually and electronically accessible information.

The Estonian ID-card facilities:

- The certificate inserted in the ID-card includes the personal identification code, which enables to identify the individual at once.
- A certificate, which enables to sign documents according to the Digital Signatures Act, is inserted in the ID-card chip.

There exists a lot of similar projects in other countries (Belgium, Finland, Italy etc.), but using of ID-card services at large you can find in Estonia as in pilot country.

# Estonian ID card



# VI eServices

**The set of facilities for the IS, which are joined to the X-Road environment:**

- Authentication (ID-card + 5 Internet bank services);
- Authorization;
- MISP (Mini Info System Portal) portal services;
- Simple queries to Estonian national databases;
- The facilities for developing complex business model queries (queries to different databases and registers);
- The writing operation into databases;
- The facility to send large amount of data (over 10Mb) from database to database over the Internet;
- Secure data exchange, logs storing;
- Queries surveillance possibility;
- The integration with citizen portal for adding new services;
- The integration with entrepreneurs portal for adding new services;
- Central and local monitoring;
- The special database for storing services WSDL descriptions.

# VII Best practice

- Parental benefit in Internet
- 5 information systems interact the data
  - Citizens' portal
  - Register of Social Insurance Board (+MISP)
  - Population register
  - IS of Health Insurance Fund
  - IS of Tax and Customs Office

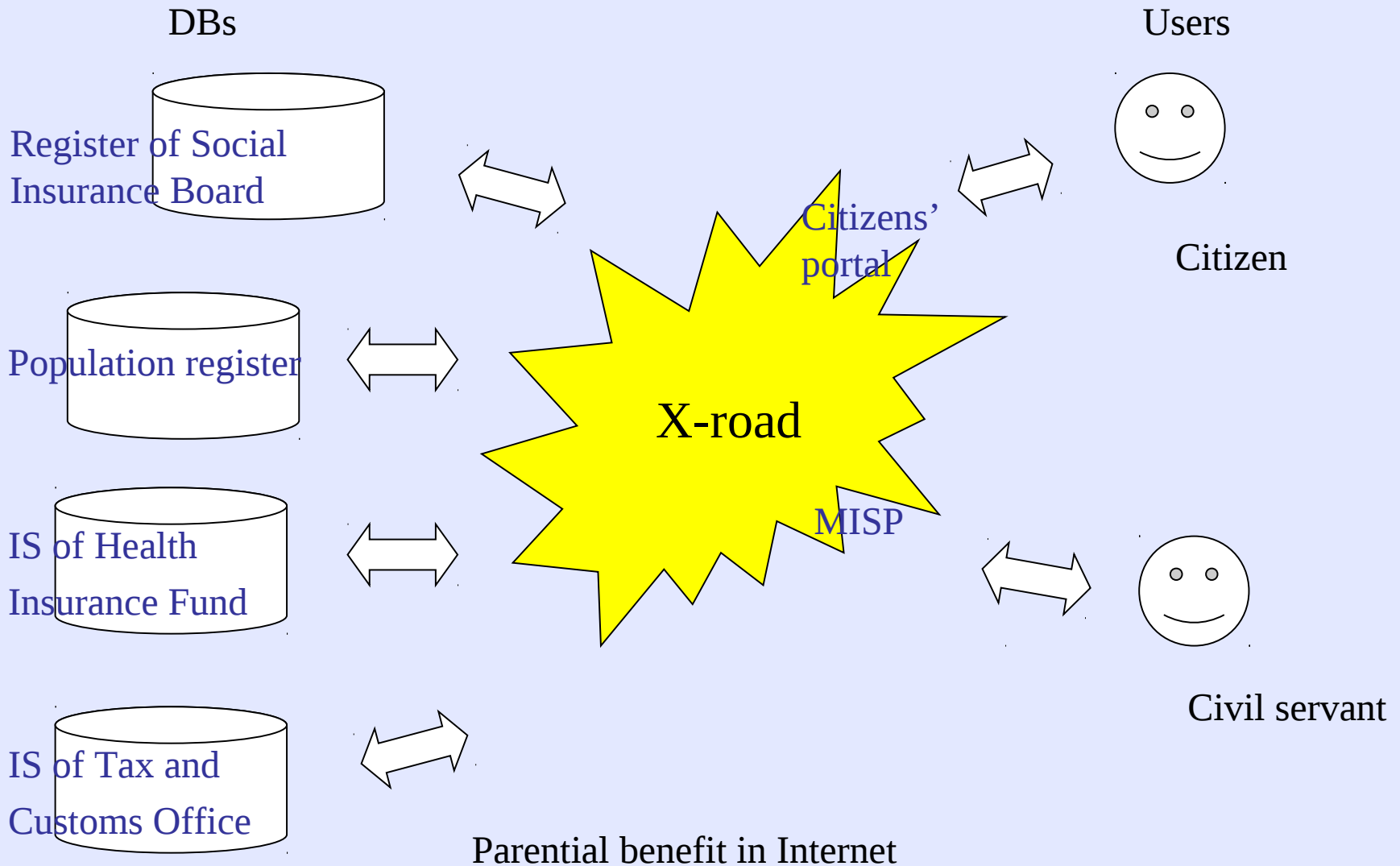

# eServices

- **ePolice**
- **eHealth**
- **eElections**
- ...
- **Internet-banking**



# Best practice for citizen

- Citizen can give applications over the Internet
- Citizen does not give data, which the IS knows anyway about the citizen
- Citizen does not fill long application documents and run from door to door
- A good example how the state has simplified the payment system

# Best practice for civil servant

- Civil servant is free from revising mountains of paper documents (7)
- Civil servant is free from inputting the data from paper documents
- Civil servant is free from checking data in different databases
- Civil servant can start the process by inputting only the personal code of client
- There does not exist any paper applications at all

# VIII Statistics

At the moment we have following clients:

- Organizations: Number of agreements – ~366

Databases/Service providers:

- All service providers: 69

Security servers:

- Number of agreements for SS: 80

# Statistics

## Services:

- The number services from all the X-road service providers ~700

## The statistics of usage:

- During the year 2003, the total number of X-road queries was: 590 000.
- Number of queries made via the X-road in 2004: over 7.75 million
- Daily record of queries in 2004: 118 000 queries per day
- Number of queries made via the X-road in 2005: over 13.45 million

# IX Conclusions

We are sure that our projects for eGovernment framework development and portals are making significant contributions to the process of moving towards the information society. Our environment represents Estonian and European best practice in the application and usage of new technologies in order to provide eServices to citizens, to civil servants and to entrepreneurs.

Minu teenusteportaal - Microsoft Internet Explorer

File Edit View Favorites Tools Help

Address: <https://www.eesti.ee/portaal/portaal.sisene?level=3&loc=>

Links: Customizable Links Free Hotmail Windows Windows Marketplace Windows Media

Teabeportaal

Kodanikuportaal

Tere tulemast! Neljapäev, 21. juuli 2005

[Esilehele](#)

### Kodanikuportaaali sisnemine

Valitud teenus(õ)e kasutamiseks on vajalik autentimine panga kaudu või ID kaardiga. Sisenemisega aktsepteerite [Kodanikuportaaali kasutamistingimusi](#).

ID kaardiga sisnemiseks peab kasutajal olema **ID kaart**, arvutiil küljes ID kaardi lugeja ja installeeritud vajalik **tarkvara**, mis ühendab omavahel eelnimetatud vahendid ja tagab ID kaardi kasutamise erinevates isiku tuvastamist vajavates internetikeskkondades.

ID kaardiga tuvastatud kasutaja saab kasutada järgmisi Kodanikuportaaali teenuseid:

- **Digitaalne allkiri** - siin saate saata ja vaadata Teile saadetud digitaalselt allkirjastatud dokumente ning kontrollida allkirja kehtivust
- **Ametlikud vormid** - siin saate täita ja saata erinevate riigiasutuste blankette
- **Registrite teenused** - siin saate vaadata Teie kohta erinevatesse riiklikesse registritesse kogutud andmeid ja esitada erinevaid taotlusi, näiteks taotleda peretoetusi (Pensionikindlustuse register), EL ravikindlustuskaarti (Haigekassa andmekogu), vaadata riigieksamite tulemusi.
- **Lingimärkmiku teenus** - lingimärkmik on mõeldud linkide säilitamiseks ja kasutamiseks ka siis, kui kodu- või tööarvuti linkide nimekiri pole kättesaadav, samuti saab lingimärkmiku abil tellida ametlikule e-posti aadressile teavituse selle kohta, kas viidatud lehekülj on viimase 24 tunni jooksul muutunud
- **Ametliku e-posti (@eesti.ee) suunamise teenus** - siin saate korraldada oma @eesti.ee postiaadressi ümbersuunamise
- **Teavitusteenus** - teavitusteenus võimaldab tellida asutuste või ettevõtete poolt edastatavaid teateid, mis puudutavad konkreetset aadressi või asukohta

[Sisenen ID kaardiga](#)



**Sisenen panga kaudu**

Panga kaudu sisnemiseks peab kodanik olema internetipanga klient. Internetipanga vahendusel pakuvad isiku tuvastamise teenust järgmised pangad:  
Hansapank, SEB Eesti Ühispank, Krediidipank, Sampo Pank, Nordea Pank.

Panga vahendusel tuvastatud kasutaja saab kasutada järgmisi Kodanikuportaaali teenuseid:

- **Digitaalne allkiri** - siin saate vaadata Teile saadetud digitaalselt allkirjastatud dokumente ning kontrollida allkirja kehtivust
- **Ametlikud vormid** - siin saate täita ja saata erinevate riigiasutuste blankette
- **Registrite teenused** - siin saate vaadata Teie kohta erinevatesse riiklikesse registritesse kogutud andmeid ja esitada erinevaid taotlusi, näiteks taotleda peretoetusi (Pensionikindlustuse register), EL ravikindlustuskaarti (Haigekassa andmekogu), vaadata riigieksamite tulemusi.
- **Lingimärkmiku teenus** - lingimärkmik on mõeldud linkide säilitamiseks ja kasutamiseks ka siis, kui kodu- või tööarvuti linkide nimekiri pole kättesaadav, samuti saab lingimärkmiku abil tellida ametlikule e-posti aadressile teavituse selle kohta, kas viidatud lehekülj on viimase 24 tunni jooksul muutunud
- **Ametliku e-posti (@eesti.ee) suunamise teenus** - siin saate korraldada oma @eesti.ee postiaadressi ümbersuunamise
- **Teavitusteenus** - teavitusteenus võimaldab tellida asutuste või ettevõtete poolt edastatavaid teateid, mis puudutavad konkreetset aadressi või asukohta

start

Sisse - Microsoft Outl...  
Ettekanded  
Teabeportaal: Esileht...  
Minu teenusteportaal...  
Microsoft PowerPoint ...

Local intranet net

11:39

The screenshot shows a Netscape 6 browser window with the URL <https://portaal.riik.ee/x/kodanik/index.php?fp=querylist>. The page content is in Estonian and features a sidebar on the left with navigation links like 'News', 'Stocks', and 'Search'. The main content area is titled 'Päringud' (Queries) and lists several services with search options:

- Päringud**
- Liiklusregister**
  - Isiklike sõidukite päring
  - Juhilubade päring
- Rahvastikuregister**
  - Kodaniku päring iseenda kohta rahvastikuregistrist
  - Kodaniku võimalus teavitada oma andmetes vea leidmisest registri volitatud töötlejale kodanikuportaaali vahendusel
  - Kodaniku võimalus teavitada oma statistiliste andmete (rahvus, emakeel, haridus, tegevusala) muutumisest
- Äriregister**
  - Kodaniku päring iseenda kohta äriregistrist
- KMA infosüsteemi andmekogud**
  - Isikukaart
- Väikelaevaregister**
  - Minu väikelaeva andmed

The browser's status bar at the bottom indicates 'Document: Done (0.531 secs)'.

X-tee kodanikuportaal. Isiklike sõidukite päring - Netscape 6

File Edit View Search Go Bookmarks Tasks Help

https://portaal.riik.ee/x/kodanik/index.php?fq=autoregister/autoregister.paring1.v2 Search

Home My Netscape Search Shop Bookmarks Net2Phone

Tat >> Paring

Päringu id: d5d6a1819e657d4ea1fe0e17a6ceb21582d9b42b

Sõiduk	Registreerimismärk	658MBS
	Mark	VOLKSWAGEN
	Mudel, modifikatsioon	VENTO
	Värvus	ROHELINE
	Ehitusaasta	1997
	Kategooria	M1
	Kere tüüp	SEDAAN
	Mootori tüüp	BENSIIN
	Mootori maht	1598
	Mootori võimsus	55
	Võõrandamine	Lubatud
	Ärandus	Ei
	Registerpandi järjekoha number	0
	Omaniku aadress	...NN, HARJUMAA
	Omaniku nimi	ARTO KESK...

Buddy Shopping Today's

Document: Done (5.939 secs)



# Thank you!